



reddot winner 2021

Segway Navimow

Choose Life Without Boundaries



2023

The Future of the Robotic Mower Industry



Find out if Navimow is
an ideal fit for your lawn.

In 1999, Segway was established in Bedford, NH, US, and has become a global enterprise in intelligent short-distance transportation and service robots. Segway products currently benefit more than 7.7 million users worldwide.

Navimow robotic mower is Segway's entry into the gardening and outdoor tools industry. Unlike most commercially available mowers, it does not require boundary wires. In addition, centimeter-level precise positioning and systematic mowing pattern increase efficiency and help ensure perfectly manicured lawns.

This revolutionary mower furthers our mission to expand the boundaries of daily life through technology.

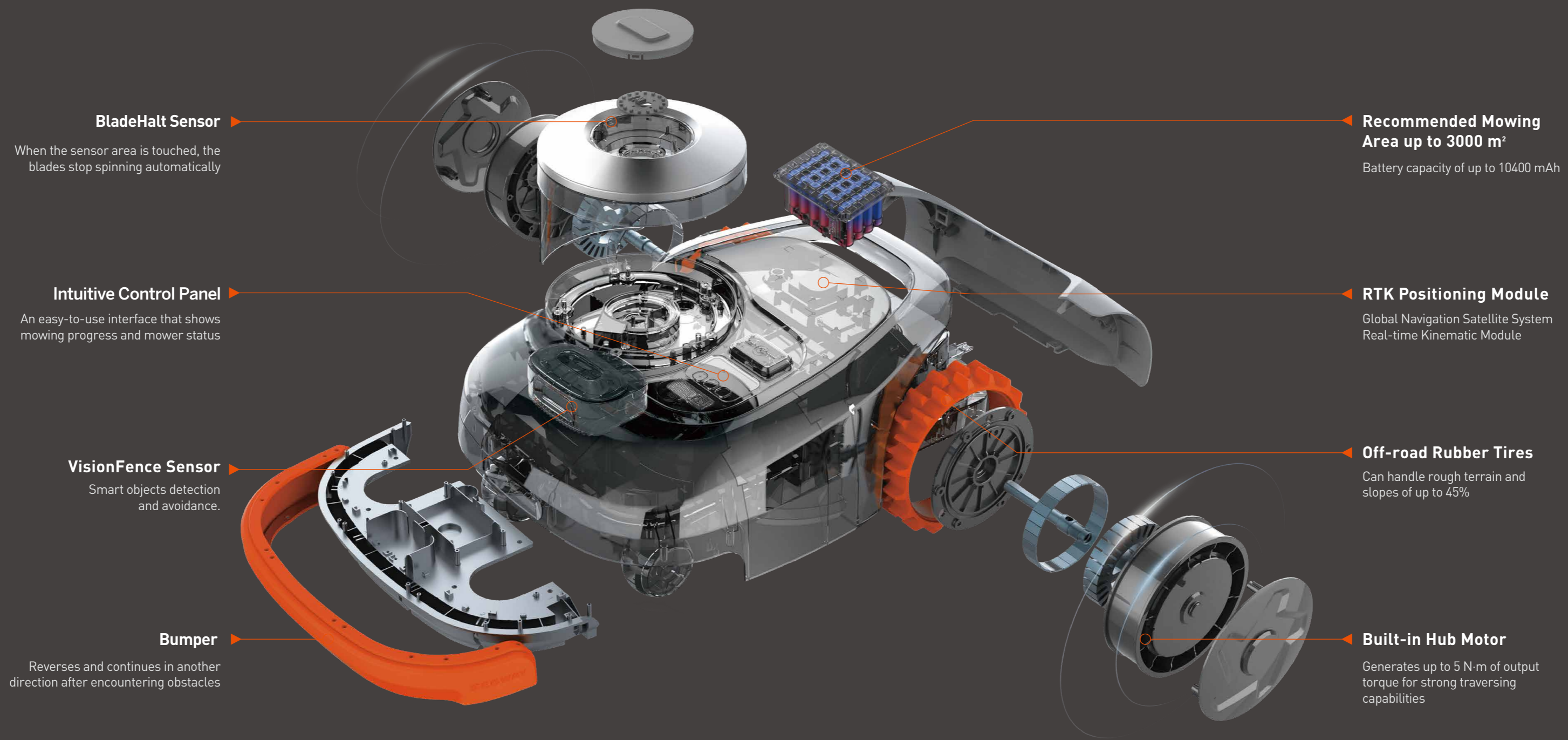

BladeHalt Sensor

When the sensor area is touched, the blades stop spinning automatically

Intuitive Control Panel

An easy-to-use interface that shows mowing progress and mower status

VisionFence Sensor

Smart objects detection and avoidance.

Bumper

Reverses and continues in another direction after encountering obstacles

Recommended Mowing Area up to 3000 m²

Battery capacity of up to 10400 mAh

RTK Positioning Module

Global Navigation Satellite System Real-time Kinematic Module

Off-road Rubber Tires

Can handle rough terrain and slopes of up to 45%

Built-in Hub Motor

Generates up to 5 N·m of output torque for strong traversing capabilities

No More Perimeter Wires

With Exact Fusion Locating System (EFLS), Navimow can improve positioning accuracy to eliminate the need for physical perimeter wires. You can easily set a virtual boundary, and make adjustments via the Navimow app. The mower will work efficiently in a planned route within the mapped out area.



Systematic Mowing Pattern

Precise positioning allows the mower to move in a planned path, cutting grass systematically. This significantly improves cutting efficiency and leaves fewer tracks on the lawn.



How Does the Exact Fusion Locating System (EFLS) Work?

The GNSS base station antenna and the mower can receive the signals from the satellites. Meanwhile, the charging station transmits the signals between the mower and the base station. This simultaneous data analysis minimizes transmission-related errors.

Even so, GPS signals can still get lost because of blockage. The Navimow's system is designed to fuse all the information with devices like the gyroscope, accelerometer, magnetic compass, barometer, and odometer. As a result, the mower can get centimeter-level position accuracy even if the GPS signal is lost temporarily.

Simply put, EFLS fuses satellite-based positioning with data from multiple sensors, guaranteeing highly accurate positioning. The mower cuts systematically within the virtual boundary mapped out by EFLS, delivering a revolutionary mowing experience.



Install the Charging Station and the Antenna

To ensure strong signal from GNSS, the antenna needs to be installed in an open space with an unobstructed view of at least 110° of the sky.

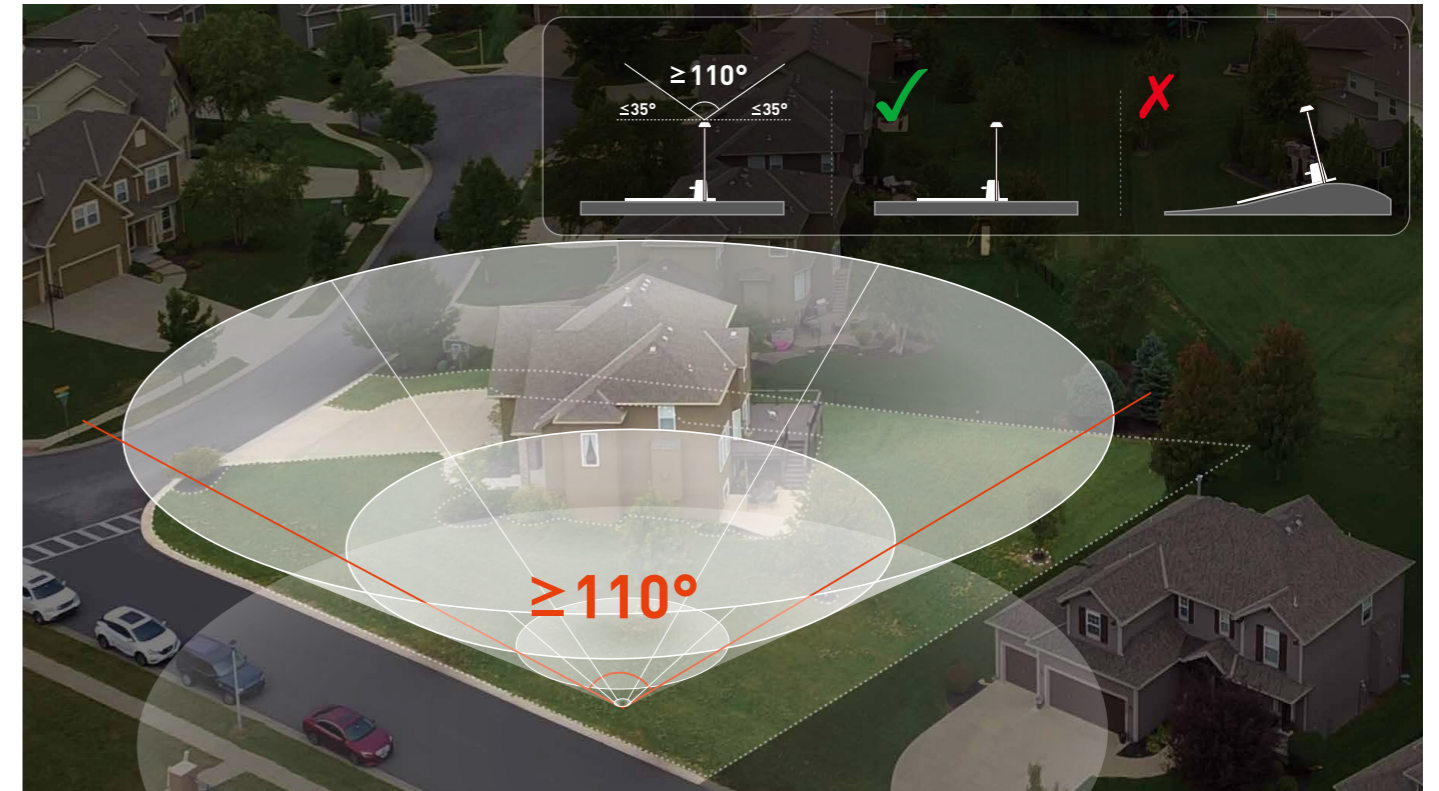

To get better signal, you can purchase the antenna extension kit and install it according to the provided instructions, ensuring an unobstructed sky view of at least 160°.

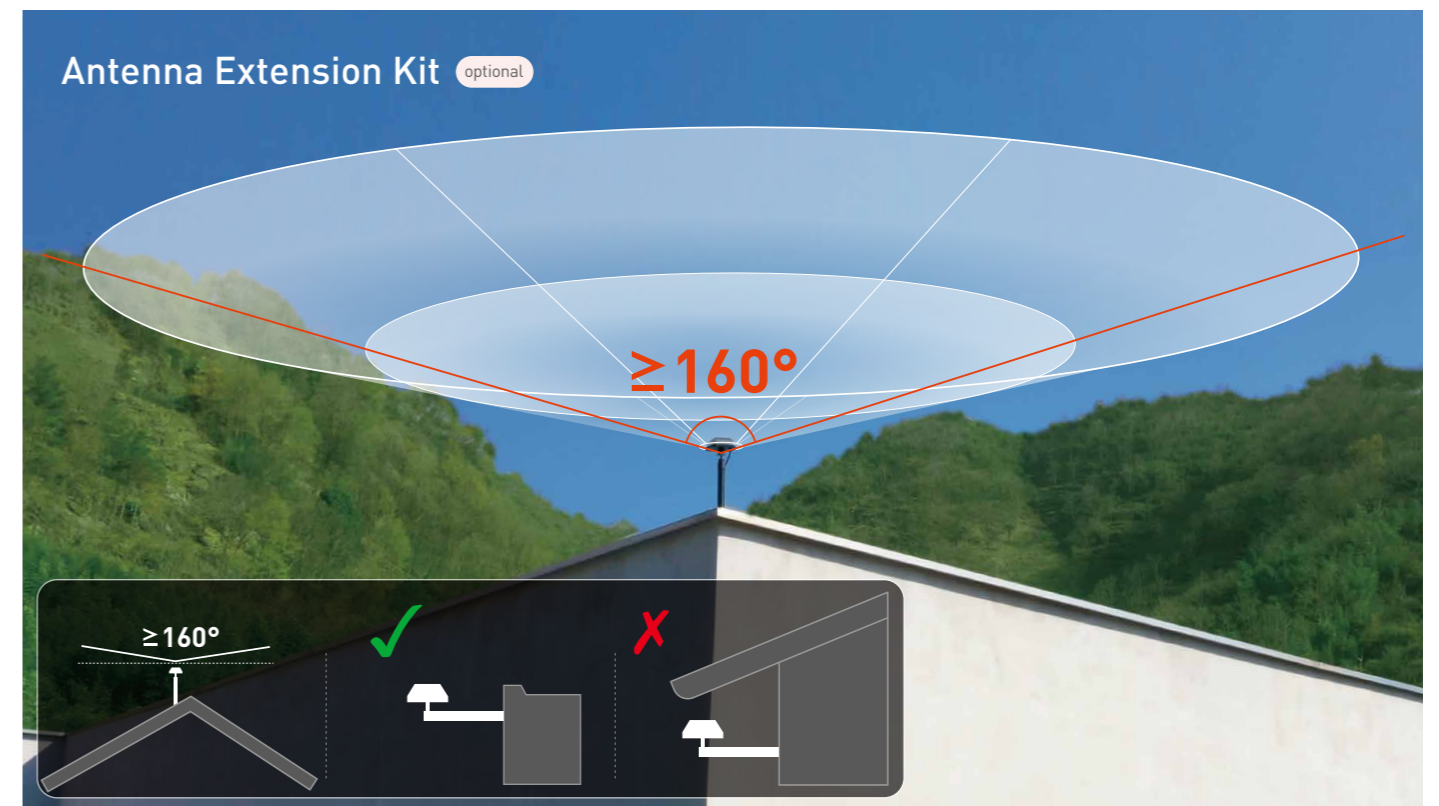

VisionFence Sensor: New accessory

With AI inside, VisionFence Sensor enables your Navimow to detect various objects and mow even more intelligently.



Adaptable to More Complex Yards

When the satellite signal is weak in areas with challenging layouts, the VisionFence Sensor can identify the lawn's edge and allow Navimow to keep mowing the lawn.



Enhanced obstacle avoidance

Thanks to the advanced visual recognition algorithm, the sensor can recognize obstacles more effectively. With the VisionFence Sensor, Navimow can recognize and actively avoid objects within 1.5 m ahead and larger than 0.1 m in diameter. Consequently, some obstacles, such as trees and flowerpots, can be avoided without being set as off-limit islands.



Wide Detection Range

See a full range within a distance of five meters and a wide angle of 140°.



Capture Every Move

Accurately capture moving objects and react in time.



Easy Set-up

Install and go. Compatible with all Navimow H-series products.



Easy Update

Get software updates via Wi-Fi connection.



Easy Clean

IPX7 waterproof level, easy to clean.





54 dB(A) Ultra-low Noise

Navimow is so far the quietest mower on the market, operating at a noise level just a bit higher than an electric toothbrush. Compared to traditional push and riding mowers, you'll hardly hear it working.

IPX6 Waterproof Level

IPX6 waterproof level ensures powerful protection against heavy sprays of water. You can easily wash it clean with a garden hose.

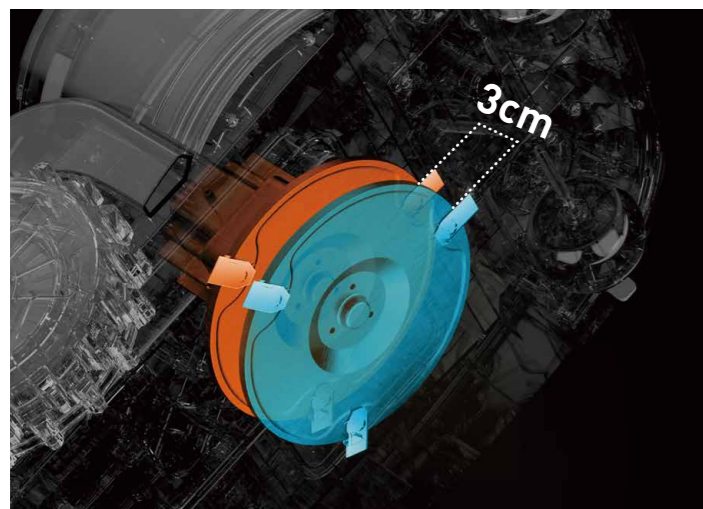

Electric Cutting Height Adjustment

Navimow is equipped with an electric motor for the blade disk. 7 blade disk height positions available from 30 mm to 60 mm, you can easily adjust it through Navimow app.



Equipped for Complex Terrains

Two hub motors are installed into the wheels to ensure stronger climbing capability. The uniquely designed rubber tires also promise strong grip. Because of this, Navimow can easily handle slopes of up to 45% and handle complex lawns.

Perfect Lawn Maintenance

The automatic mowing path optimization system allows Navimow to select the optimal mowing path and automatically change the mowing direction after completing a round of mowing. Avoids the traces left by repeated mowing paths and keeps your lawn in a healthier growth environment.



Safer than Ever

Navimow has multiple built-in safety sensors, including an IMU and Lift sensor for front and rear lifting, and Ultrasonic and Bump sensors for obstacle avoidance. The BladeHalt^[1] sensor provides an extra layer of safety, stopping the blades if an object has contact with the sensing area.

^[1] This Lab function needs to be turned on in the app, because some water-rich plants will also trigger bioelectric induction, which may cause false detection. Optimization is in progress.

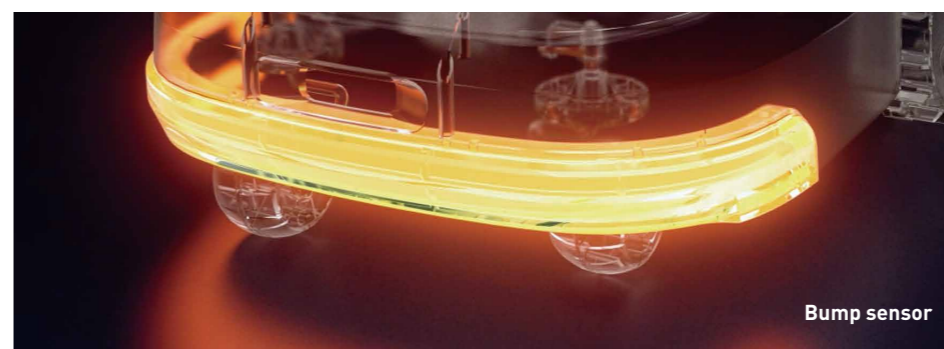
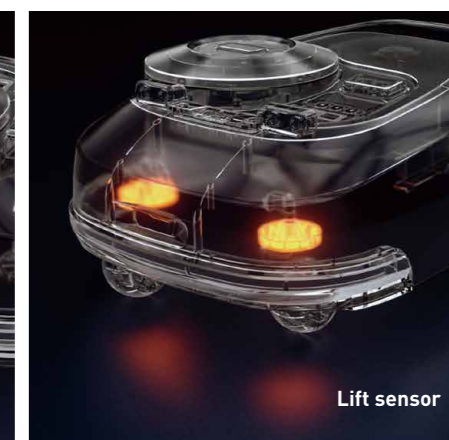
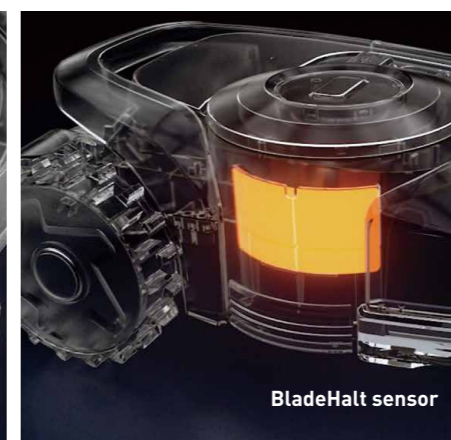
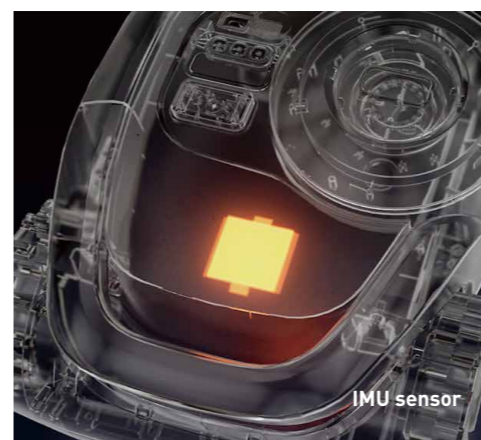

CHOOSE LIFE 
WITHOUT BOUNDARIES



Navimow App: Perfect Lawn Care With Just a Tap

To download the Navimow app, scan the QR code below or search "Navimow" in the App Store or Play Store.

GOLD AWARD 2022

Play Store

App Store

Smart App Control

In the Navimow app, you can find everything you need, from interactive guidance and personalized settings to status updates and service extension.



Set and Adjust Mowing Area



Check Real-time Mower Status



Adjust Mowing Schedule



Set an Anti-theft Alarm



OTA Updates

How to Choose a Robotic Lawn Mower

Among all the robotic mowers, why is Navimow the best choice? In a word, Navimow is smarter, more efficient, and easier to use:

Virtual Boundary

Avoid the hassle of laying boundary wire in your lawn. Just map out a virtual boundary in the app.

Boundary Wire

Spend hours of time and effort with your wire, hammer, ruler, and spikes.

Systematic Mowing Pattern

Systematic routes and efficient work, flawless cutting.

Random Mowing Pattern

Random routes and time-consuming, repetitive cutting.

IoT Connectivity

Remotely Operate and monitor the mower with ease from anywhere at any time. To ensure you always have the latest features, you can download over-the-air (OTA) updates with just a tap in the app.

No IoT Connectivity

The mower cannot be controlled or monitored remotely. Updating can only be done with a USB flash disk.

With No Perimeter Wires, Setup Is a Breeze

Download the Navimow app and follow the instructions to set up the virtual boundary. Navimow is built to adapt quickly, so even when the garden lawn layout changes, you can quickly and easily redefine the virtual boundary to reflect those changes.



1 Verification
Verify your Segway Navimow Checklist result.

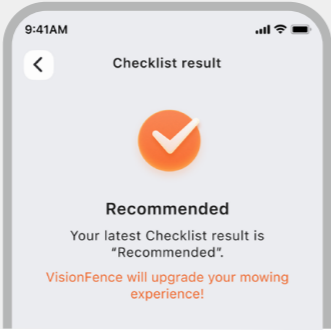

+ VisionFence Sensor

1

2 Activation
Connect your Navimow to a network and activate it.



2

3 Mapping
Follow the guidance in the app to create a map.

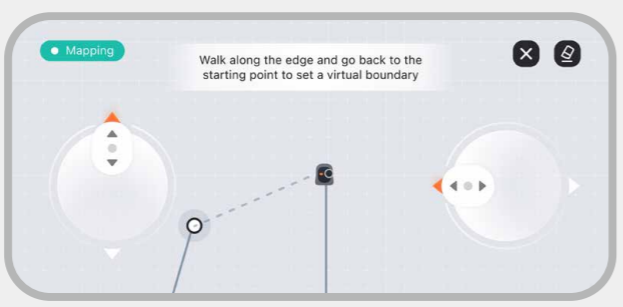

3

4 Testing
Tap "Test" to validate the established boundaries. Navimow will travel along the boundaries to test the map.

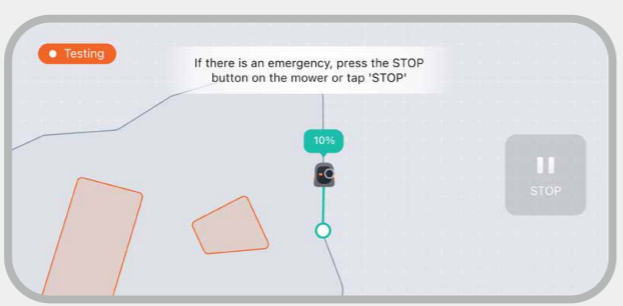

4

With VisionFence Sensor, you can skip testing and start to mow.

5 Mowing
You can manually start the mower, start it in the app, or set up a schedule.

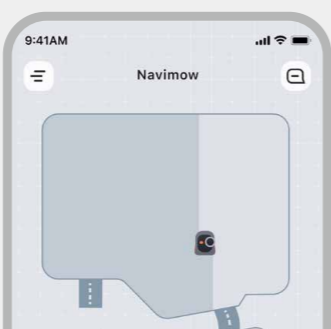

4

Features	H500E	H800E	H1500E	H3000E
Dimensions	603 × 468 × 264 mm	603 × 468 × 264 mm	603 × 468 × 264 mm	603 × 468 × 264 mm
Net Weight	15.6 kg	15.6 kg	15.9 kg	16.3 kg
Recommended Mowing Area	500 m ²	800 m ²	1500 m ²	3000 m ²
Cutting Height	30–60 mm	30–60 mm	30–60 mm	30–60 mm
Cutting Width	21 cm	21 cm	21 cm	21 cm
Battery	5.2 Ah	5.2 Ah	7.8 Ah	10.4 Ah
Run Time	180 min	180 min	240 min	240 min
Charging Time	180 min	180 min	240 min	300 min
Max. Slope	45%	45%	45%	45%
Noise	54dB (A)	54dB (A)	54dB (A)	54dB (A)
Waterproof Level	IPX6	IPX6	IPX6	IPX6
Virtual Boundary	●	●	●	●
Systematic Cutting Path	●	●	●	●
Automatic Charging	●	●	●	●
Mulching	●	●	●	●
Off-road Driving	●	●	●	●
BladeHalt Sensor	●	●	●	●
Ultrasonic Sensor	○	○	○	●
Wi-Fi	●	●	●	●
4G	-	●	●	●
App Control	●*	●	●	●
In-app Height Adjustment	●*	●	●	●
Streamlined Interface	●	●	●	●
GPS Anti-theft Protection	-	●	●	●
Easy Cleaning	●	●	●	●
Rain Sensor	●	●	●	●
OTA Updates	●*	●	●	●
PIN Code	●	●	●	●

○ optional ● Series - unavailable
* The Navimow H500E model requires a Wi-Fi network covering the whole area, to be able to use all functions optimally.

All data are nominal values

Accessories

VisionFence Sensor New

All-new visual recognition technology, bringing upgraded obstacle avoidance and better adaptation to complex yards



Dimensions
158 x 110 x 60 mm



Packaging Material
Color Box



Part No.
HA104



Ultrasonic Sensor

For smart obstacle avoidance



Dimensions
290 x 81 x 46 mm



Packaging Material
Color Box



Part No.
HA101



Blade Assembly

Easy blade replacement for the whole year



Dimensions
110 x 190 x 12.5 mm



Packaging Material
Blister Card



Part No.
HA002E



Antenna Extension Kit

Improves GPS signal for antenna installation on the wall or roof



Dimensions
165 x 82 x 255 mm



Packaging Material
Color Box



Part No.
HA001



Temporary Fence

Protects areas where you don't want the mower to go



Dimensions
345 x 345 x 50 mm



Packaging Material
Color Box



Part No.
HA003



Extension Cable

Extra extension cable for antenna installation on the wall or roof



Dimensions
120 x 200 x 45 mm



Packaging Material
Color Box



Part No.
HA103

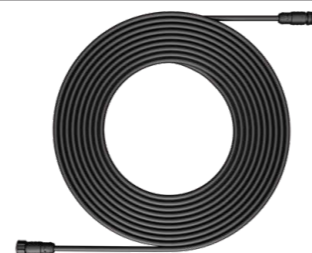

Benefits of Navimow



Virtual Boundary

Easy setup with no perimeter wires required

Systematic Cutting Path

Improves the cutting efficiency significantly

Off-road Driving

Off-road tires, built-in hub motor, 45% slope-climbing capability



Electric Cutting Deck

30-60 mm adjustable cutting height with 7 available positions



Smart App

Easy access and control from anywhere, at any time



Anti-theft

Sends auto alert if the mower is outside the boundary



Easy Operation

User-friendly and intuitive control panel



Internet of Things (IoT)

Remote control, monitoring and over-the-air updates



Labor Saving

Say goodbye to complicated operation and maintenance



Time Saving

Free up your schedule and spend quality time in your yard



Maximum Safety

Multiple built-in safety sensors



IPX6 Waterproof Level

Cleanable with a garden hose



Ultra-low Noise

Noise level minimized to a barely audible 54 dB(A)



No Pollution

No fuel burning or CO₂ pollution thanks to lithium-ion batteries



Healthy Cutting

Cuts a little bit each time and cuts more frequently



CHOOSE LIFE
WITHOUT
 BOUNDARIES

Notes

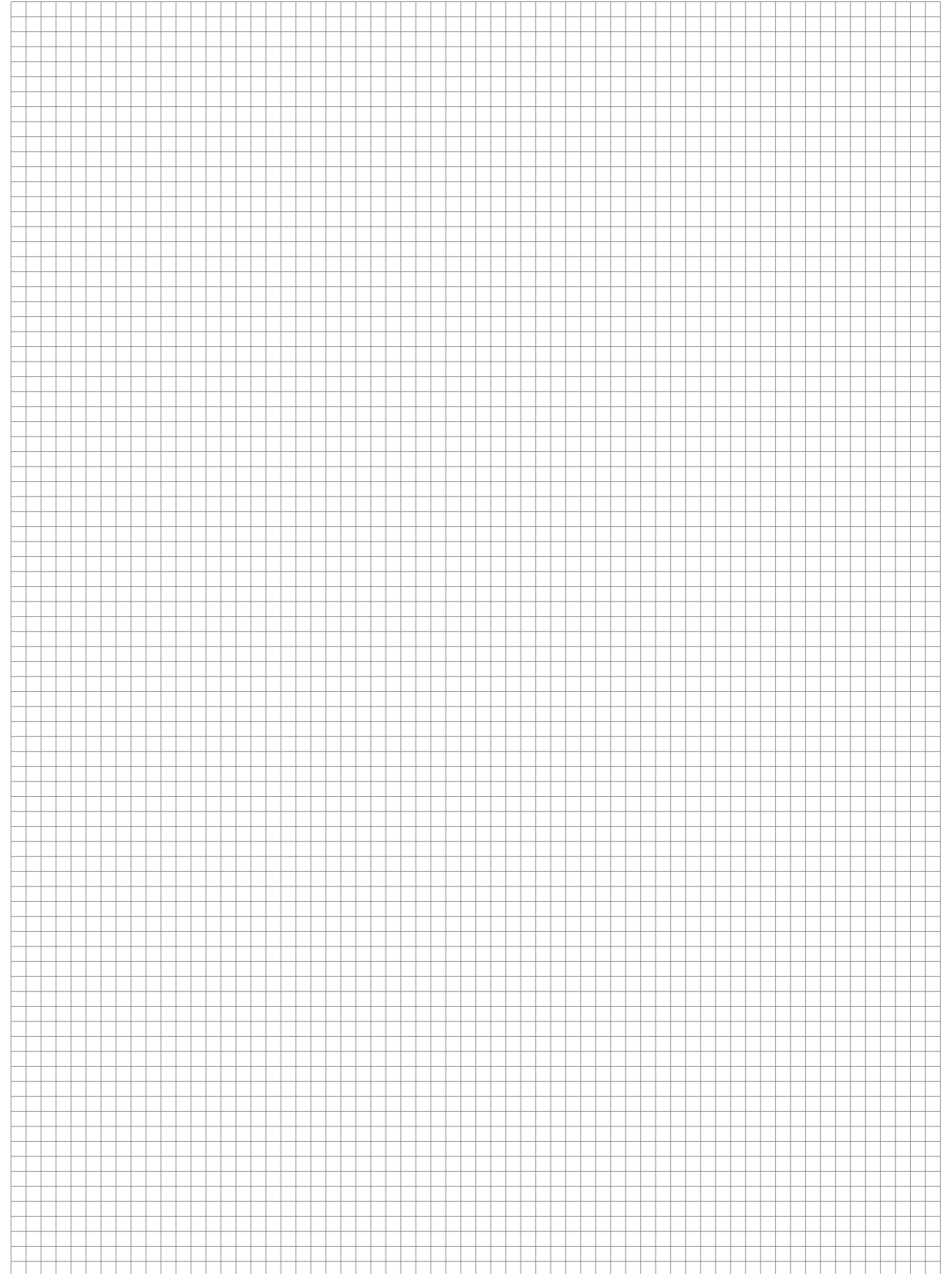
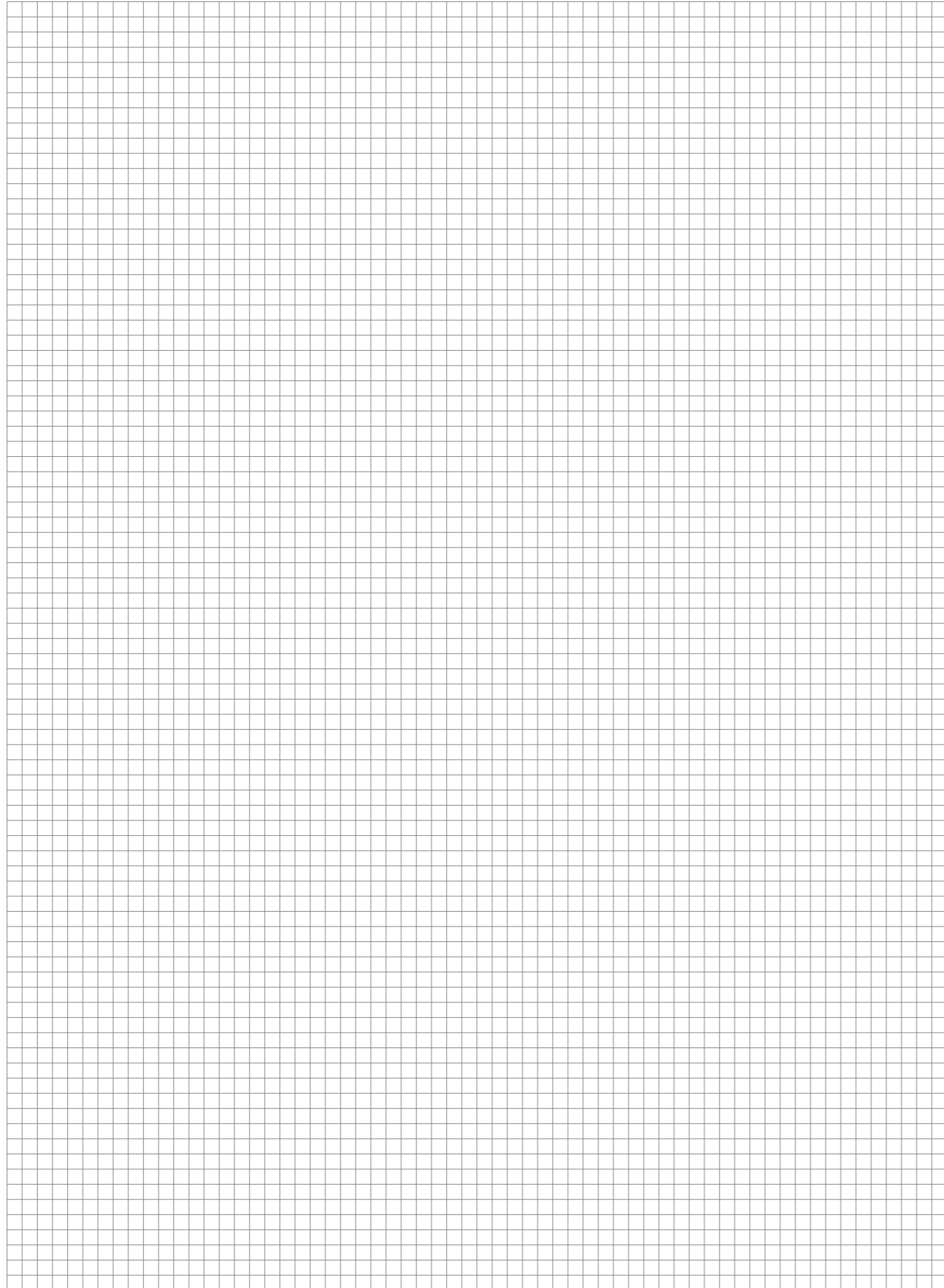

CHOOSE LIFE
WITHOUT
 BOUNDARIES



<https://navimow.segway.com>

Business Inquires: navimow@rlm.segway.com
After-sales Service: support-navimow@rlm.segway.com
Facebook: @Segway Navimow
YouTube: @Segway Navimow6192
LinkedIn: @Segway Navimow

The manufacturer reserves the right to make changes to the product, and update the prices and specifications at any time. Please visit navimow.segway.com for more information.